

Time Allowed : 3 Hours

If the questions attempted are in excess of the prescribed number, only the questions attempted first up to the prescribed number shall be valued and the remaining ones ignored.

Answers may be given either in English or in Bengali but all answers must be in one and the same language.

GROUP - A

Answer any six questions

- State de Broglie's hypothesis. What is the ratio of the kinetic energy of an electron to that of a proton if their de Broglie wavelengths are equal 2+3
 - Write down ground state wave function of hydrogen atom and show that radial probability density is maximum at the Bohr radius. 5
- Starting from time-dependent Schrodinger equation in one-dimension, derive the equation of continuity. 5
 - Obtain the spectral designation of the level whose degeneracy is 7 and the quantum numbers L and S are interrelated by $L=3S$. Why non-polar homonuclear molecules do not exhibit infrared rotation-vibration spectra? 3+2
- Which statistics is obeyed by an atomic nucleus? What do you mean by classical limit of quantum statistics. 3+2
 - Two identical particles, each of them can be in one of the three possible states of energy 0, E and $2E$. Find the number of micro-states of the system for MB, BE and FD-statistics. 5
- Define binding fraction of nuclei and sketch its variation with mass number of the nuclei. Which nuclear phenomenon can be explained from the lower- A part of the binding fraction curve. 2+2+1
 - If a nucleus with $A=235$ splits into two fragments with mass numbers in the ratio of 3:2, find the separation between the fragments at the moment of splitting. Given $r_0=1.4 \times 10^{-15} \text{ m}$ 5
- Predict the characteristics of the ground state of ${}^8\text{O}^{17}$ using shell model. Find the Q -value of the nuclear reaction ${}^{14}\text{N}(n, \alpha){}^{11}\text{B}$ is MeV . Given mass of ${}^{14}\text{N}=14.007550 \text{ u}$, ${}^{11}\text{B}=11.012811 \text{ u}$, $n=1.008987 \text{ u}$, ${}^4\text{He}=4.003879$ and $1 \text{ u}=931 \text{ MeV}$. 2+3
 - Identify the unknown particle in the reaction:

$$\pi^- + p \longrightarrow K^0 + t \dots$$
 Given an analysis of the nuclear reaction 2+3

$$\pi^- + p \longrightarrow \Lambda^0 + K^0$$
 in terms of quarks.
- Find the reciprocal lattice of a sc lattice. Show that greater the diffraction angle, the greater is the accuracy in determining the lattice parameters. 2+3
 - Draw the different branches of the dispersion relation curve within 1st Brillouin Zone. Why are they so called? 2+3

7. (a) Give a comparative study of conductor, semiconductor and insulator. What are the sources of electrical resistance in solids? 4+1
- (b) State Curie-Weiss Law and discuss its significance. A paramagnetic material has 10^{28} atom/m³. Its susceptibility at 350 K is 2.8×10^{-4} . Calculate the susceptibility at 300 K. 3+2
8. (a) Establish the relation between \mathcal{L} and β of a transistor. (where symbols have their usual meaning) 5
- (b) Draw the output voltage of the following op-amp circuit when 1V dc is applied to its input. Draw the output waveform upto 10 sec. 4+1
9. (a) Draw the drain characteristics of an n-channel MOSFET indicating operation in both modes. The pinch-off voltage of a p-channel JFET is $V_p = 5V$ and $I_{DSS} = -40$ mA. The drain to source voltage V_{DS} is such that a saturated drain current $I_{DS} = -15$ mA is maintained. Find the gate-source voltage V_{GS} . 3+2
- (b) Convert the decimal number 263 in a code of base 5. Give the circuit symbol of the following logic circuit and mention the name of the gate (do not use de Morgan's theorem). 3+2

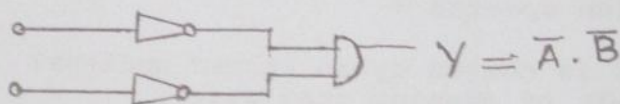

GROUP - B

Answer any seven questions

10. (a) Consider a linear harmonic oscillator for which total energy is $E = \frac{p_x^2}{2m} + \frac{1}{2} m \omega^2 x^2$, symbols have their usual meanings. The particle is assumed to be confined in a region $\sim a$. Using uncertainty principle, obtain ground state energy of the oscillator. 6
- (b) Find the ground level ($2S+1 L_T$) of the atom having electronic configuration $2p^5 3s$. 4
- (c) Consider a particle is an infinite square well of potential given by
- Obtain energy eigen-values and eigen functions. 10
11. (a) Give a theoretical account of energy splitting in anomalous Zeeman effect. 6
- (b) The first rotational Raman line of hydrogen molecule appears at 346 cm^{-1} from the existing line. What is the bond length of hydrogen molecule. 4
- Given $m(^1\text{H}) = 1.673 \times 10^{-27} \text{ Kg}$.

(c) Show that for a single step potential, as defined by

$$V(x) = 0 \text{ for } x < 0 \\ = V_0 \text{ for } x \geq 0$$

the probability of finding the particle (for $E > V_0$) at the boundary between two regions is conserved. 10

12. (a) Obtain an expression of Fermi-Dirac distribution function. 10

(b) Show that average kinetic energy of an electron at $T=0K$ is $\frac{3}{5} E_F$, where E_F is the Fermi energy. 6

(c) Show that molar specific heat at constant pressure of a monatomic gas is $\frac{5}{2} R$. 4

13. (a) Show that for a 2D free electron gas, the number of electrons per unit area is given by -

$$n = \frac{4\pi m K_B T}{h^2} \ln (e^{E_F/K_B T} + 1) \quad 10$$

(b) In a solid, consider the energy level lying 0.01 eV below the Fermi level. What is the probability of this level not being occupied by an electron. Given $K_B T = 0.026$ at 300 K. 6

(c) Show that the Zero point energy of a solid according to Debye model is $\frac{9}{8} R \Theta_D$. Where symbols have their usual meaning. 4

14. (a) Write down semi-empirical mass formula for the mass of a nucleus and mention the different terms. Obtain mass parabola from it. Mention its importance. 8

(b) The masses of the different nuclei taking part in ${}^7_3\text{Li} (p, n) {}^7_2\text{Y}$ reaction in h are as follows :

$$M({}^7_3\text{Li}) = 7.01822, \quad M({}^2_1\text{H}) = 1.00814, \quad M({}^1_0\text{n}) = 1.00898$$

and mass of product nucleus = 7.01915. Calculate the Q-value of this reaction in MeV. Is it exergic or endoergic? What is the threshold of the reaction? 8

(c) What is neutrino hypothesis of Pauli? 4

15. (a) Define hypercharge. Give the graphical plot of baryon octet and explain the diagram. 10

(b) Check whether the reaction is allowed or forbidden?



(c) Identify the particle x in the following reaction

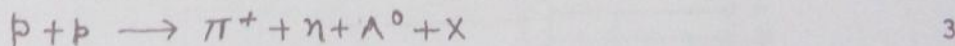

(d) State CPT theorem. Which quantum number or property is not conserved in weak interactions. 4

16. (a) In a crystal, a lattice plane cuts intercepts of $2a$, $3b$ and $6c$ along three axes, whose a , b , c are primitive vectors of unit cell. Determine the Miller indices of the plane. 7
- (b) Find the lowest energy band using Kronig-Penny model for $P \ll 1$. Given $P \frac{\sin \alpha a}{\alpha a} + \cos \alpha a = \cos ka$, terms have their usual meaning. 7
- (c) State and explain Meissner effect in superconductor. 6
17. (a) Derive Curie's Law for susceptibility on the basis of Langevin's classical theory of paramagnetism. 10
- (b) NaCl crystal has a cubic structure. If the molecular weight of NaCl is 58.46 and its density 2.71 gm/cc, find the distance between the two atoms of the same kind ($2a$) and the lattice constant (a) in the crystal. 7
- (c) Show that for the free electron model, the effective mass of electron is equal to the free electron mass. 3
18. (a) Express the decimal number -23 in 8-bit 2's complement form. Hence perform the decimal subtraction (48-23) by 2's complement method. 4

(b) Compare the outputs :

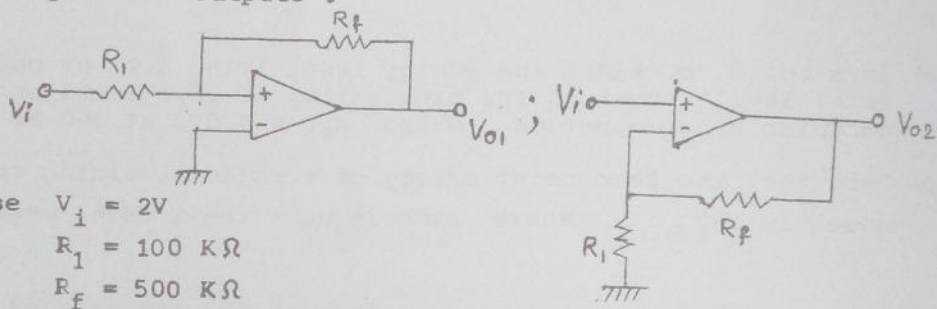

- (c) In the equivalent circuit of a vibrating piezoelectric crystal, assuming $R=0$, obtain the expression of crystal impedance. Discuss its behaviour as inductive and capacitive. 10
19. (a) In the circuit, find the quiescent values of I_E and V_{CE} . Given $\beta = 90$, $V_{BE} = 0.7V$. If β is increased by 50%, what will be the effect on V_{CE} ?

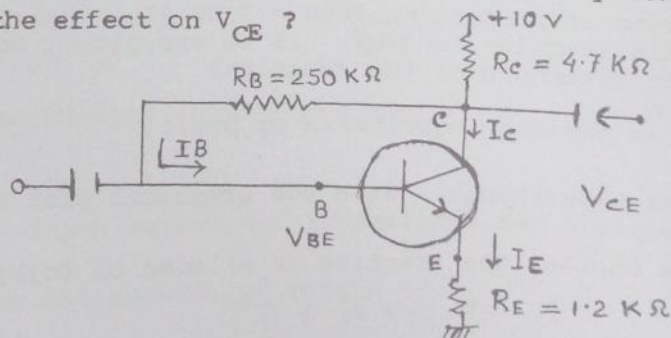

(b) Obtain the simplified logic circuit of the following one:

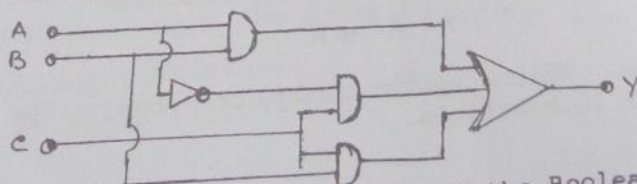

(c) Obtain the logic circuit of the Boolean function $F = AB + CD$ using two-input NAND gates only. 5